

SUPERIOR Folding Lift Shutters

Bolton Gate's Superior folding shutters offer all the advantages of a compact folding door but with the addition of an extremely robust design perfected over sixty years. The door is ideally suited to goods lifts where there is a heavy-duty requirement or where the client is seeking greater longevity. Many of the leading companies such as supermarket chains, factories, warehouses etc. specify the door as they recognise the value for money the Superior door offers particularly when ongoing maintenance is considered.



STANDARD SPECIFICATION

Gate Frame

The gate frame is formed from 3mm thick double channel vertical steel pickets interconnected by 6mm thick solid steel lattice bars. The gate frame is top hung from a ball bearing pulley connected to the picket by zinc plated pulley brackets. At the bottom, the frame is fitted with zinc plated bottom guide pieces designed to run in a bottom track.

Leading Edge

The heavy-duty leading edge is fabricated from steel channels with 3mm thick full height sideplates and is prepared for locks, latches or interlock beaks. Number 10 bow handles are fitted as standard.

Shutter Leaves

The shutter leaves are rolled from galvanised steel and are available in the standard width of 152mm with 229mm versions also available.

Top Track

The standard top track from which the shutter is suspended is constructed from two galvanised steel sections 90mm deep, bolted together to give a strong smooth running section for the shutter thus minimising friction. Only a small amount of headroom is required for the top track and variable packing is provided to allow adjustment in height during longer term service requirements.

Bottom Track

The bottom guide pieces are retained within a 25 x 25mm galvanised steel channel bottom track.

Fire Resistance

Landing doors are supplied in a fire-resisting version when specified. The door has been tested to BS 476 Part 22 1987 and BS EN 1634-1 for up to two hours fire resistance and is certified by the Loss Prevention Certification Board.

MAXIMUM SIZES

7 metres wide x 7 metres high

OPTIONS

- Vision panel
- Trigger latch
- Centre latch with handles
- Mathews catch
- VL10 gatelock
- Recessed handle
- Subframes
- Polyester powder coating
- Stainless steel

FINISH

Mainly galvanised steel with ungalvanised components finished with one coat of priming paint.

WEIGHT

Approximately 40kgs per m².

SUPERIOR

Folding Lift Shutters

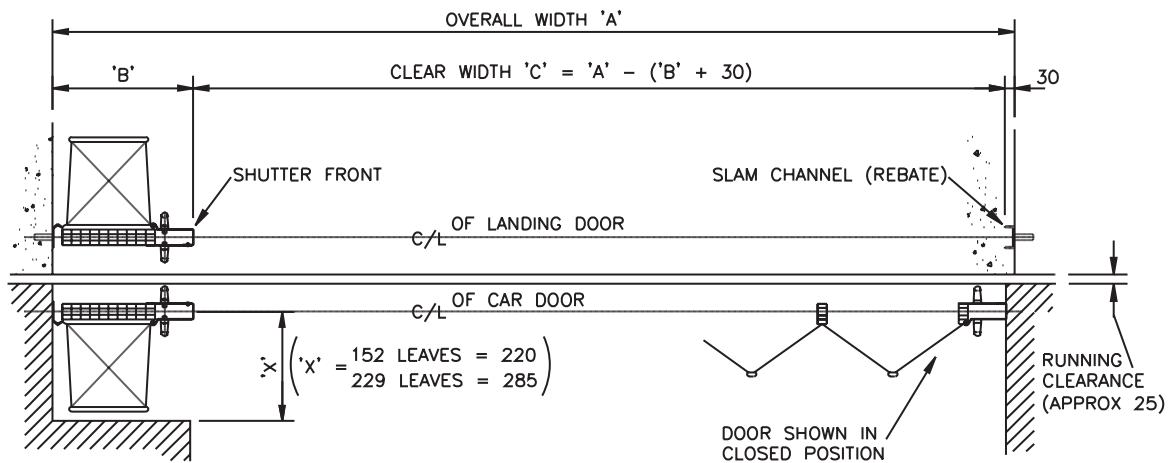
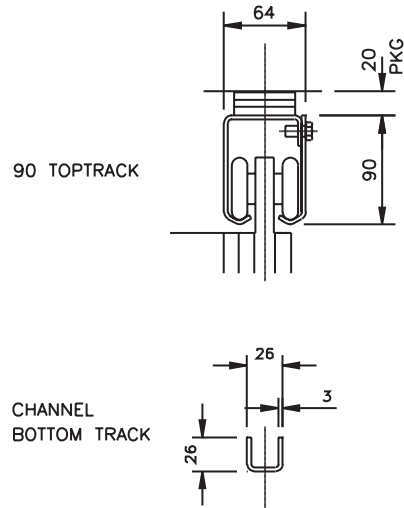
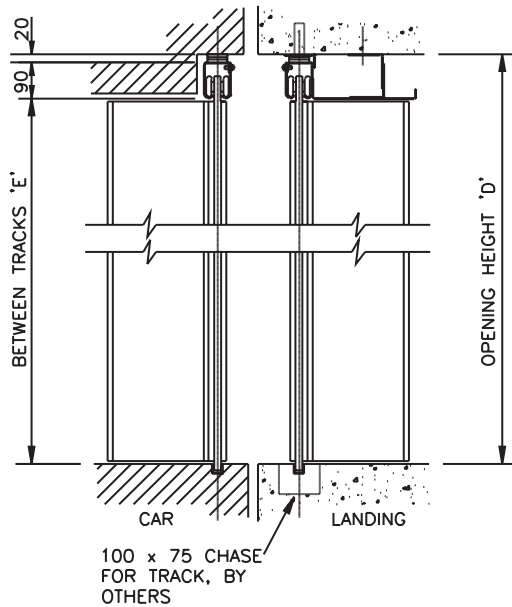

152mm LEAVES	DIM 'C'	741	1030	1295	1560	1825	2090	2355	2620	2885	3150
	DIM 'A'	1020	1312	1604	1896	2188	2480	2772	3064	3356	3648

229mm LEAVES	DIM 'C'	1185	1590	1995	2400	2805	3210	3615	4020	4425	4830
	DIM 'A'	1440	1872	2304	2736	3168	3600	4032	4464	4896	5328

BUNCH	DIM 'B'	225	252	279	306	333	360	387	414	441	468
-------	---------	-----	-----	-----	-----	-----	-----	-----	-----	-----	-----

NOTE!

THE OVERALL WIDTH AND BUNCH DIMENSIONS ARE CALCULATED USING BOLTON GATE STANDARD 117 ROLLED OR 127 FABRICATED FRONTS. TOP TRACK LENGTH = OVERALL WIDTH - 12.

ALL DIMENSIONS IN mm