

STEEL ROLLING GRILLES

Bolton Gate Steel Rolling Grilles are designed for openings where a high degree of security is required whilst maintaining the see through aspect not available with closed lath shutters. They can be used on openings where selective entry/exit is required and are ideal for shopping malls and underground car parks where they also provides optimum ventilation. The combination of parallel mesh design and polyester powder coated finish offers a high aesthetic appearance and each grille is custom made to suit the individual opening and can be face fixed or fixed between the structure.

STANDARD SPECIFICATION

Curtain

Constructed from galvanised steel tubes and links to give an attractive parallel mesh of 500 x 85mm. Continuous steel inner tubes running horizontally provide strength against bowing and are capped/pinned to prevent lateral movement. The bottom rail is formed from two steel angles.

Guides

Formed from galvanised steel with suitable guide angles provided for bolting to the opening structure.

Roller

Fabricated from steel tube of sufficient diameter and wall thickness to prevent deflection.

Endplates

Fabricated from mild steel with support angles for fixing to the opening structure. Bearings are fitted at either end to support the roller shaft.

ELECTRICAL OPERATION

The grille is powered by a geared motor which is mounted directly onto one endplate. Adjustable limit switches are provided and a facility for manual operation in the event of power failure. Each grille is provided with an open/close/stop push button starter which should be mounted adjacent to and in full view of the opening.

SPEED OF OPERATION

Approximately 100mm per second.



FINISH

Polyester powder coated to a standard BS or RAL colour.

MAXIMUM SIZES

10 metres wide x 5 metres high (maximum area: 40m²)

WEIGHT

Approximately 25 kgs per m²

OPTIONS

- Tubular Motors
- Heavy duty motors for higher usage
- Key switches
- Remote control
- Safety photocells
- Coil casings and fascias
- Solenoid locking shootbolts

STEEL ROLLING GRILLES

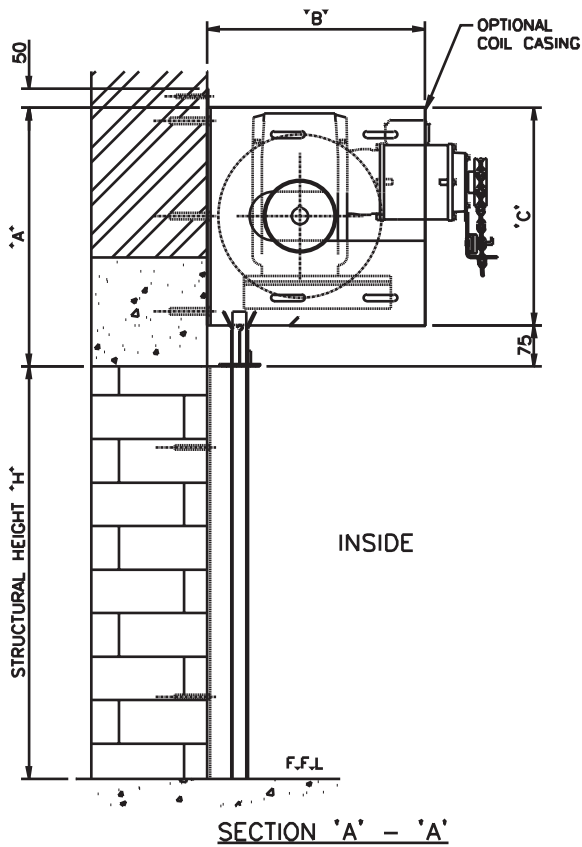

FACE FIX GUIDE DETAIL

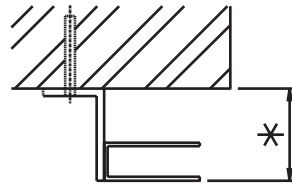

* UPTO 4500 H = 75
OVER 4500 H = 100

STANDARD BOTTOM RAIL DETAIL



	W X H	A	B	C
UP TO	5000 x 3000	600	475	525
UP TO	10000 x 3000	625	500	550
UP TO	5000 x 5000	675	550	600
UP TO	10000 x 5000	700	575	625

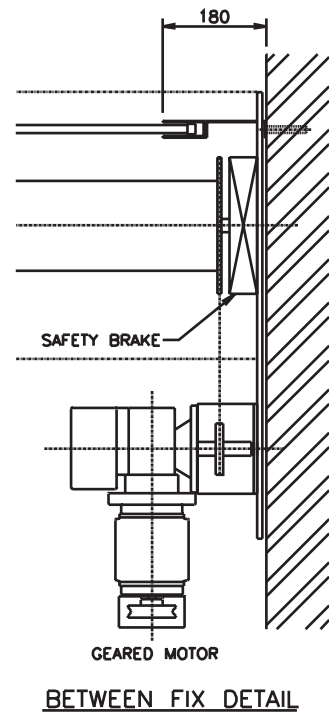
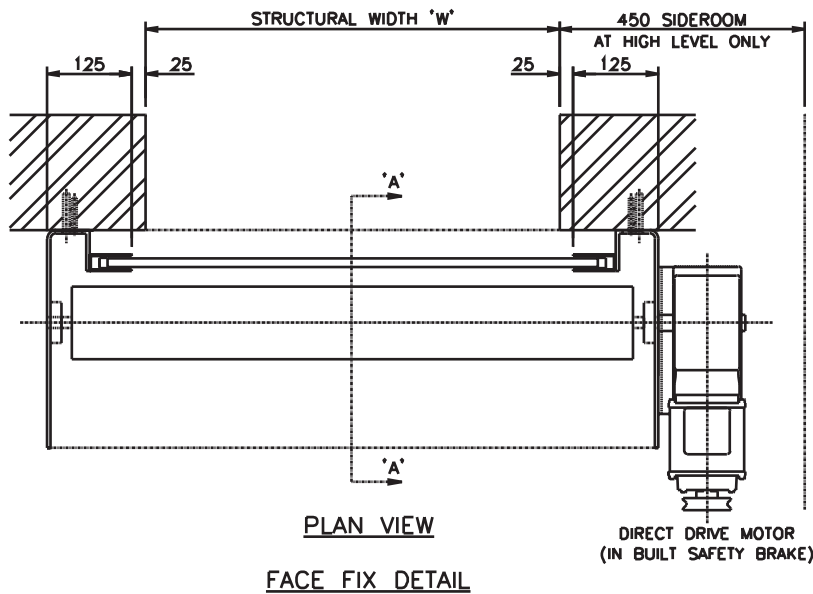

ALL DIMENSIONS IN mm.