

FIBREROLL

Horizontal Rolling Fire Curtains

Having been the market leader in vertical curtains, Bolton Gate has successfully conducted an extremely onerous test at 6 metres x 3 metres on a fire curtain in the horizontal orientation to EN 1634-1 for two hours fire resistance.

Ideally suited to provide horizontal compartmentation between floors, the Fibreroll curtain protects openings such as lightwells in schools, hospitals and commercial buildings. The small box and compact side guides minimise spatial requirements particularly compared to steel options and the combination of motor, sprung cables and solenoid ensure closure in all conditions.

STANDARD SPECIFICATION

Fire Resistance

Tested to EN 1634-1 and approved for two hours fire resistance.

Curtain

Specially reinforced and coated grey fibre glass material approximately 0.7mm thick and weighing 650 gms per m² which withstands temperatures of more than 1000 degrees C. The material is attached to the roller at one end and to a slimline steel leading edge.

Guides

The side guides are constructed from galvanised steel and prepared for fixing to the opening structure. The guide incorporates a rebate onto which the curtain bobbins engage in a pressurised fire situation thus preventing excessive deflection.

Casing

The casing is manufactured from galvanised steel and is 475mm wide x 300mm deep. It may be soffit or face fixed to the structure.

Endplates

Fabricated from galvanised steel and supplied with angles for fixing to the structure.

Roller

The roller is manufactured from mild steel tube of sufficient diameter and wall thickness to resist deflection and is mounted in bearings on each end plate.

OPERATION

The curtains are electrically operated as standard using a 240 volt single phase Speedsafe motor which incorporates an electro magnetic brake, adjustable limit switches and a built in control panel.

The design incorporates a failsafe closure system as standard with normal activation in fire conditions via an auto re set



solenoid which on receipt of a 24 volt DC fire signal, releases the motor brake and allows sprung cables mounted within the side guides to close the curtain.

As a back up device, a fusible link is also incorporated into the system which closes the curtain when localised heat reaches 68 degrees C. In all instances, closure is effected in a controlled manner.

The standard system is pre wired in our factory to avoid the costs of site electricians and merely requires a 240 volt IEC socket within one metre of the motor position.

FINISH

The guides, bottom rail and casing are supplied galvanised as standard. They are also available in stainless steel and polyester powder coated in a range of standard RAL colours at extra cost.

MAXIMUM SIZES

3 metres wide x 6 metres long.

SPEED OF OPERATION

Approximately 75mm per second.

WEIGHT

Approximately 30 kgs per linear metre of perimeter.

OPTIONS

- Audible and/or visual alarms
- Various fixing arrangements
- Polyester powder coated finish
- Auto re-set magnet

FIBREROLL

Horizontal Rolling Fire Curtains

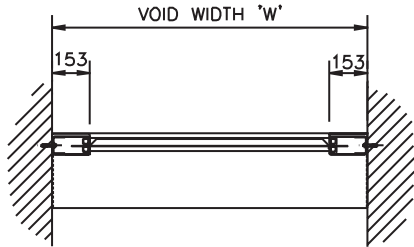

SECTION 'A-A'
FIX BETWEEN

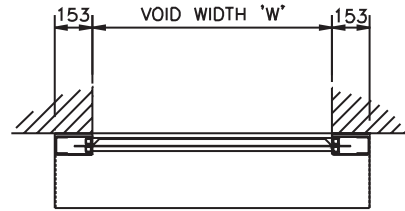

SECTION 'A-A'
SOFFIT FIX

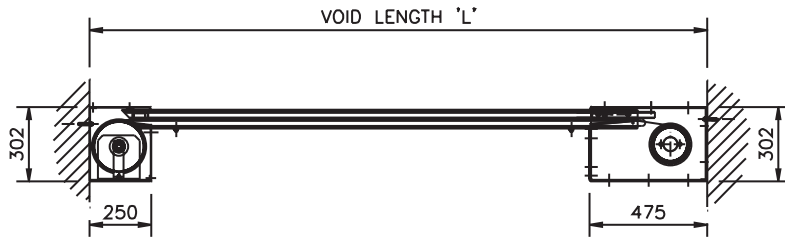

SECTION 'B-B'
FIX BETWEEN

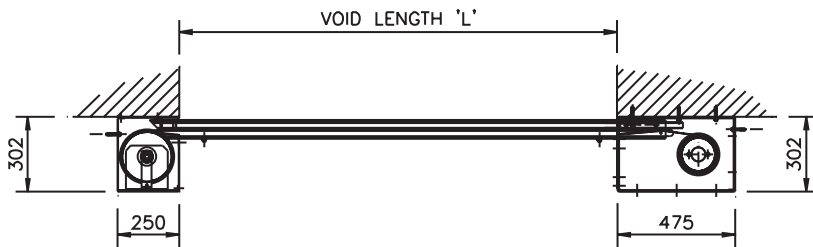

SECTION 'B-B'
SOFFIT FIX

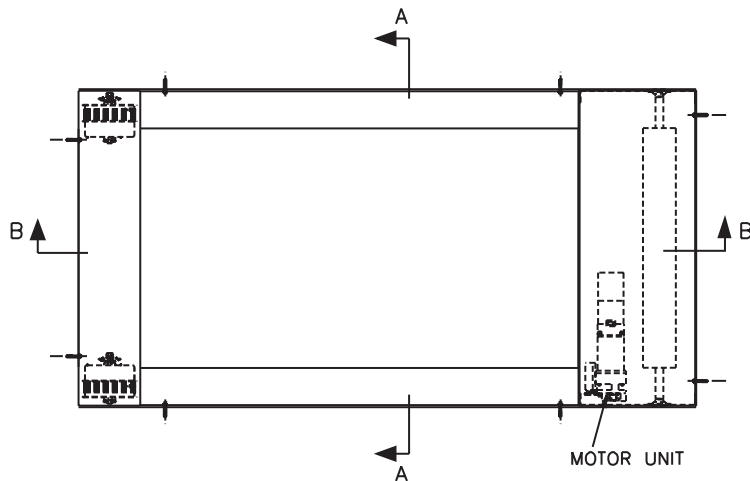

PLAN ON VOID