

FIBREROLL AO

Rolling Fire Curtains

Bolton Gate Company, the acknowledged leader in the field of rolling fire door technology, introduces a revolutionary product designed to provide AO class fire resistance between fire compartments but with a product with a fraction of the weight of equivalent steel products and much-reduced sideroom and headroom requirements.

The Fibreroll Rolling Fire Curtain, which has been successfully tested to IMO Resolution A754 (18) for AO class fire resistance, offers major advantages over existing traditional fire doors allowing ship design new horizons in terms of fire compartmentation.

GENERAL SPECIFICATION

Curtain

Specially reinforced and coated fibre-glass material which is designed to withstand temperatures in excess of 1000 degrees C.

Steel bobbins are attached to each end of the fabric to ensure that the curtain remains in the side guides even when subjected to differential pressures caused by fire.

The curtain thickness is approximately 0.7mm and the weight 480 grams per square metre.

A steel bottom rail is attached to provide rigidity and act as a weight to assist closure.

Guides

Manufactured from galvanized steel and formed into a slimline profile which is prepared for bolting to the bulkhead. Integral rebates are incorporated on which the bobbins engage in a fire situation.

Roller

The roller comprises a 101mm diameter steel tube in which the tubular motor is fitted at one end and steel shafts / discs at the other. The roller is supported at each end on galvanized steel endplates with integral angles for fixing to the bulkhead.



Casing

The roller is covered by a galvanized steel casing which also acts as a fire seal at the head.

OPERATION

The Fibreroll curtain is electrically operated using a 24 volt DC tubular motor. A control panel is mounted at high level which has an inbuilt facility for an incoming fire signal, and which converts /rectifies the incoming single phase mains supply allowing the batteries to operate the motor. Should the mains supply fail, the curtain closes by gravity.

A low level push button is supplied for everyday use.

FINISHES

The curtain is self finished in grey with the side guides and roller casing galvanized as standard. The metalwork is also available in stainless steel or a polyester powder coated finish in a wide range of RAL colours.

MAXIMUM SIZES

2660mm wide x 2653mm high

OPERATING SPEED

Approximately 75mm per second

WEIGHTS

Curtain: 480 grams per square metre.

Roller / casing: 30 kgs per linear metre

FIBREROLL A0

Rolling Fire Curtains

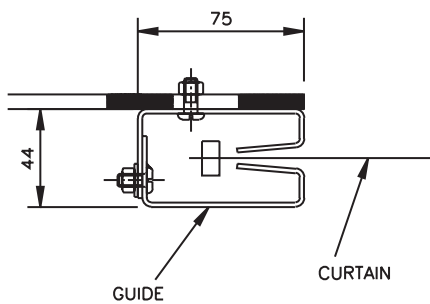

GUIDE DETAILS

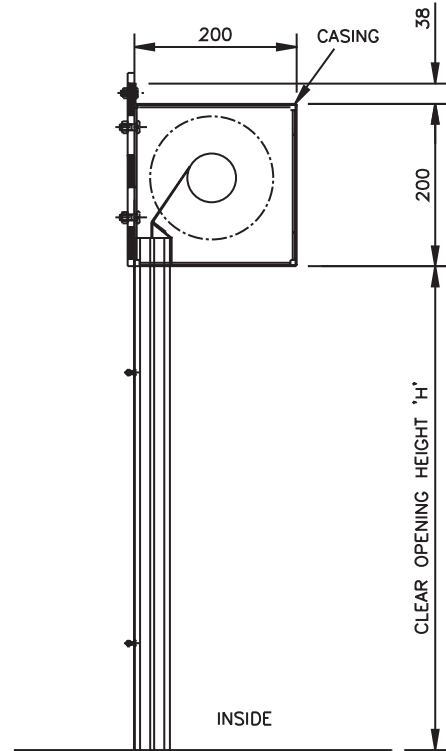

SECTION

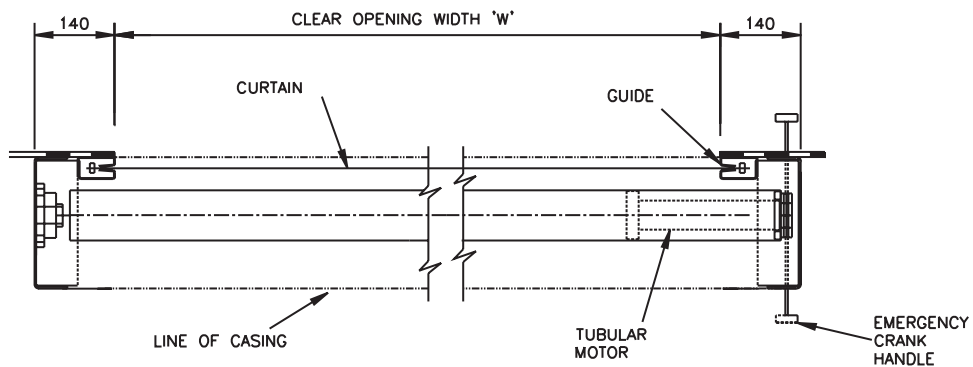

PLAN

ALL DIMENSIONS IN MILLIMETRES