

BRICKBOND Rolling Grilles

Bolton Gate Brickbond Rolling Grilles offer the ultimate through-vision concept of all grilles and shutters whilst affording protection to bars and server counters with an attractive yet unobtrusive security barrier. The product is compact in design requiring a minimum of sideroom and headroom and is available in a range of attractive finishes and colours.

Electrical operation by tubular motor allows ease of use without potential Health and Safety issues associated with manually operated shutters.

GENERAL SPECIFICATION

Curtain

Constructed from aluminium tubes and links arranged in a brickbond pattern with a mesh size of 230 x 70mm. Internal horizontal rods are manufactured from 8mm diameter round bar and pinned at each end to prevent lateral movement.

Bottom Rail

Mill finish aluminium inverted "tee" section.

Guides

The side guides are formed from 38 x 29mm extruded aluminium channels and prepared for fixing to the opening structure. Fixed and intermediate guides in 90°, 135° and 180° versions are available.

Endplate

Fabricated from mild steel of adequate thickness relative to door size and supplied with angles for fixing to the structure.

Roller

The roller is manufactured from mild steel tube of sufficient diameter and wall thickness to resist deflection and is mounted in bearings or cups on each end plate.

Finish

Mill finish as standard. A silver anodised or polyester powder



coated finish in a range of standard RAL colours is available at extra cost.

Weight

Approximately 20 kgs per m².

Operation

Electrical operation is by means of a single phase tubular motor. A safety brake is fitted to all shutters where personnel could pass underneath thus meeting all relevant Health & Safety requirements. The client should provide a fused spur within 500mm of the motor position.

Controls

The standard method of control is by means of internal wall-mounted rocker switch. Other types of control including keyswitches and group controls are available at extra cost.

Casings

Coil casings fabricated from galvanised steel sheet are available as optional extras.

BRICKBOND

Rolling Grilles

ELECTRIC (TUBE MOTOR)

FACE FIXED

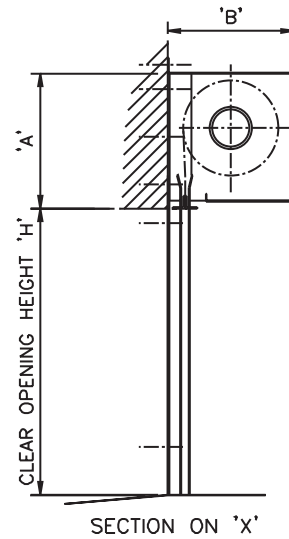
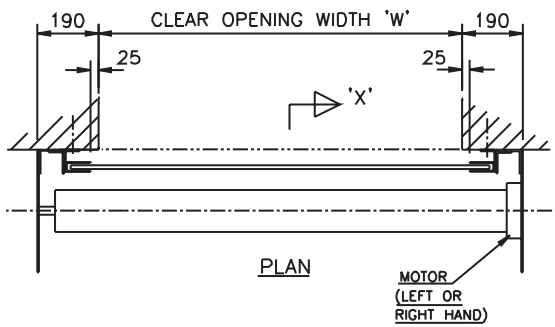

BETWEEN FIXED

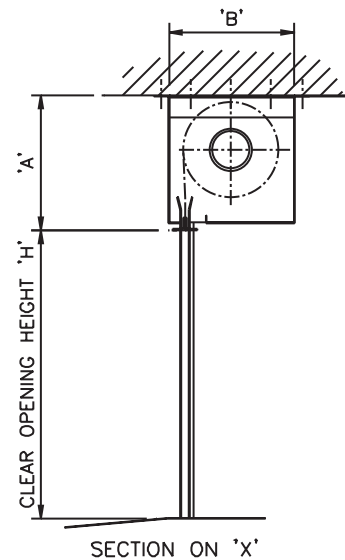
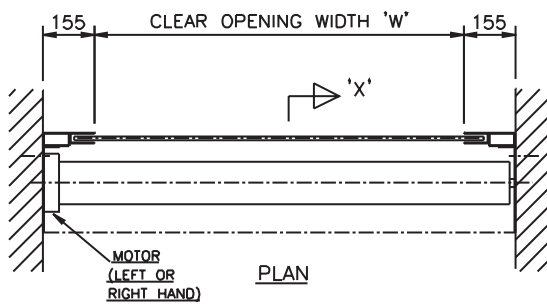

HEIGHT	ENDPLATE SIZE	
	'A'	'B'
2900	300	300
3600	350	350
4000	400	400
5000	450	450